

chillR / chillR ^{PLUS}

KOOLSPACE TM

WINE AND PANTRY COOLING SYSTEM



INSTALLATION & OPERATION MANUAL

READ BEFORE YOU START

Koolspace cooling units must be installed precisely as directed in the Manual.

DO NOT attempt to install this unit before reading the Manual!

1. **NEVER** Install this unit through an exterior wall, **NEVER** to OUTDOORS! (Units must ventilate to an adjacent INTERIOR space, Warm air vents must be completely unobstructed).
2. Install the unit in an enclosure where ALL surfaces (walls, floor and ceiling) are insulated to R-20 and protected by vapor barrier on both sides.
3. Uninsulated concrete floors will radiate heat and humidity during summer months, forcing the unit to work harder than necessary, the life of unit will be shortened, and will produce EXCESS CONDENSATION.
4. Install the unit in a location where the condenser (warm side) coil is accessible for periodic vacuuming of the condensor coil. (See troubleshooting for details.)
5. Outlet power must be a DEDICATED separately fused and grounded 15-Amp 115 Volt line within reach of supplied power cord (Europe; 10-Amp 220 Volt). Line must not be shared with any other outlet or appliance. (Insufficient voltage will cause the unit not to run, compressor may not start, and the LED display may be corrupted).
6. Extension cord must not be used.
7. Electronic controller must also be protected against sudden power surges. Koolspace wine cooling systems may be damaged by power surges or spikes, sudden interruptions or prolonged low-voltage conditions.
8. You must monitor your unit DAILY. If unit is in "Alarm", unplug the unit immediately. Always check for any water (condensate) leaks. (Check troubleshooting section)
9. Koolspace TM will not be liable or responsible for incidental or consequential damages. (See Warranty).
10. Third party servicing of these units during the warranty period will void the warranty.
11. Select a suitable area, sized appropriate to the model's capacity, in a location where ambient temperature will not exceed the desired storage temperature by more than 25°F (14°C).
12. This appliance is for INDOOR USE ONLY, and must not be vented into a laundry closet or similar room which traps warm air.
13. The unit must vent to an adjacent INTERIOR VENTILATED SPACE CLOSE TO THE CEILING. Exhaust air must not be obstructed in any way.
14. The temperature of the air in the immediate area where the unit vents its warm air must never exceed 80°F with 70% R.H. (non-condensing). Operating temperatures are: Outside of wine cellar: min. 65°F (18°C) Max. 80°F (26°C) / Inside of wine cellar: min. 52°F (11°C) Max. 64°F (18°C)

WARNING: Lower SET TEMPERATURE FROM DEFAULT 57°F (14°C) only if ambient conditions allow. A lower set temp can cause water overflow in high humidity conditions.

SPECIAL NOTE: THIS COOLING UNIT IS CONSTRUCTED FOR INSTALLATION IN WALLS UP TO 7 1/2" INCHES THICK. IF YOU INSTALL IT IN A THICKER WALL YOU WILL HAVE TO CUT OUT AN AREA AROUND THE AIR VENTS ON THE COLD SIDE IN ORDER NOT TO BLOCK THE AIRFLOW.

HARDWARE :



WASHER (4)

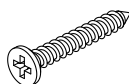

6 x 1" (20)

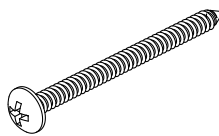

6 x 1 3/4" (6)

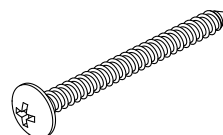

8 x 1 3/4" (4)

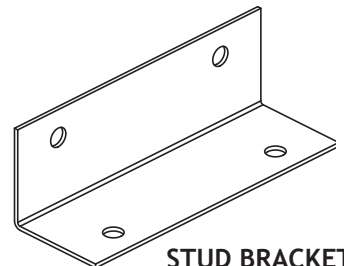

STUD BRACKET (4)

PREPARING FOR INSTALLATION

Koolspace C-series is the only unit that allows for isolating the studs against noise and vibration when installed as directed.

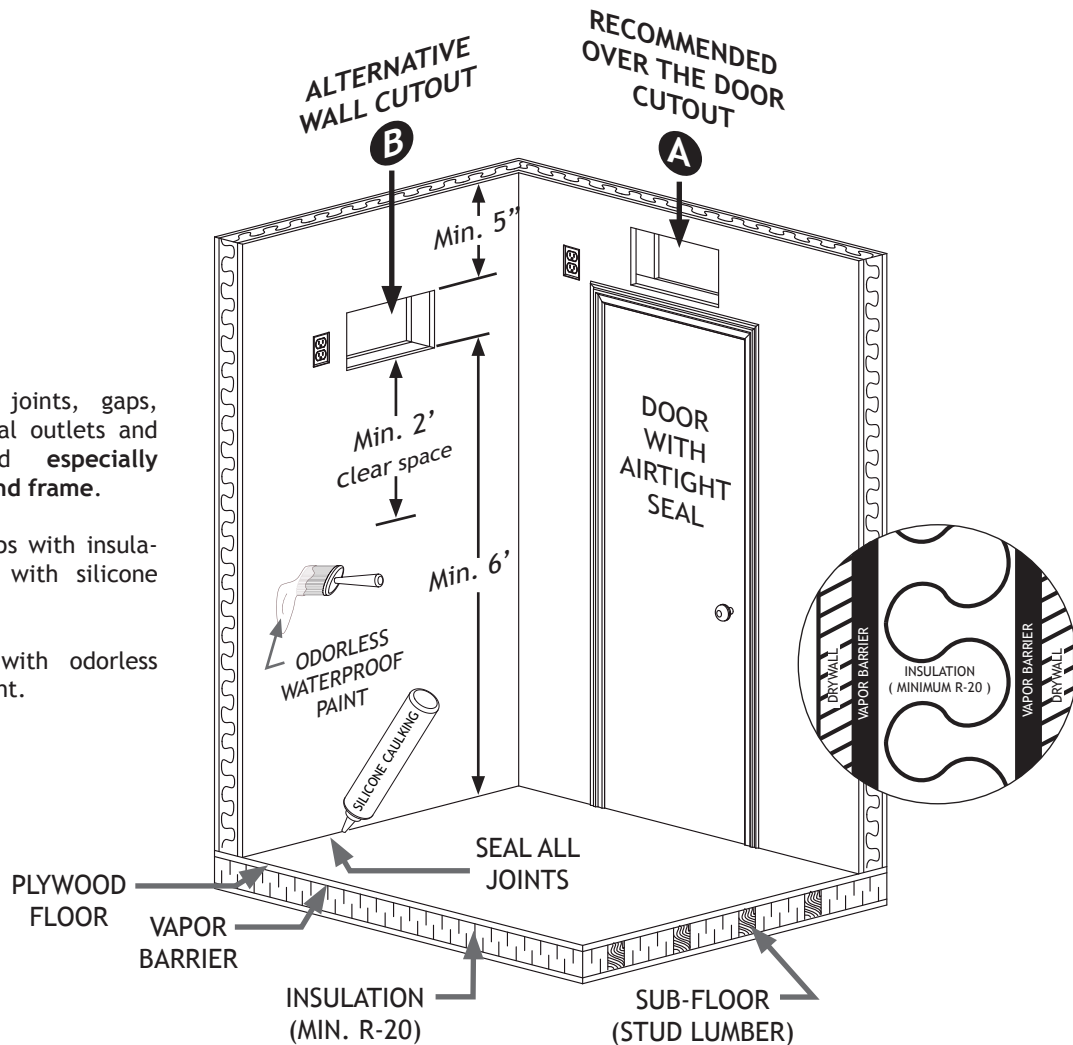

SEAL

Seal corners, joints, gaps, vents, electrical outlets and switches, and especially around door and frame.

Pack larger gaps with insulation. Seal all with silicone caulking.

Seal drywall with odorless waterproof paint.

VAPOR BARRIER

All surfaces of the enclosure must be protected by a proper vapor barrier, ideally on both inside and outside of wine cellar.

INSULATION

Floor, ceiling and all walls of the enclosure must be insulated to minimum R-20 rating, although R-30 is recommended.

Best material is foil-backed urethane foam, sealed at all joints with thermal tape.

Build a proper sub-floor with vapor barrier, and insulate to at least R-20, especially if floor is concrete.

POWER SUPPLY:

This unit must be installed in accordance with national wiring regulations.

Do not use if power cord is damaged; it must be replaced by the manufacturer or its service agent or by a qualified person to avoid a hazard. Plug must remain accessible after installation.

Electrical service must be a dedicated, separately fused and grounded 15 Amp, 115V line (Europe; 10-Amp 220 Volt).

Do not share the circuit with any other appliance. Test line voltage BEFORE operating, and do not use if line voltage is less than 105V. The unit must be protected against power surges and spikes: use a good quality surge suppressor.

A OVER THE DOOR CUTOUT

THE FOLLOWING STEPS ARE COMMON FOR 8' FOOT CEILINGS

This manual is only a guide, house structure may vary. (For high ceilings install an upper horizontal brace)

START ON THE WARM SIDE

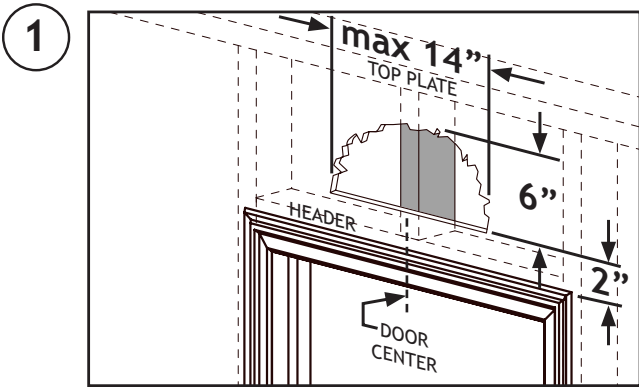

Open drywall on warm side. Measure distance from HEADER to TOP PLATE and MOLDING. Follow the typical installation described in STEPS 2-6 if clearance is 10" and the HEADER is at least 3/8" higher than the molding. (SEE PROFILE)

IF YOU DO NOT HAVE CLEARANCE

Customize your installation to meet the required dimensions (SEE DETAIL).

TIP: - Increase headroom (cut TOP PLATE with utility saw)

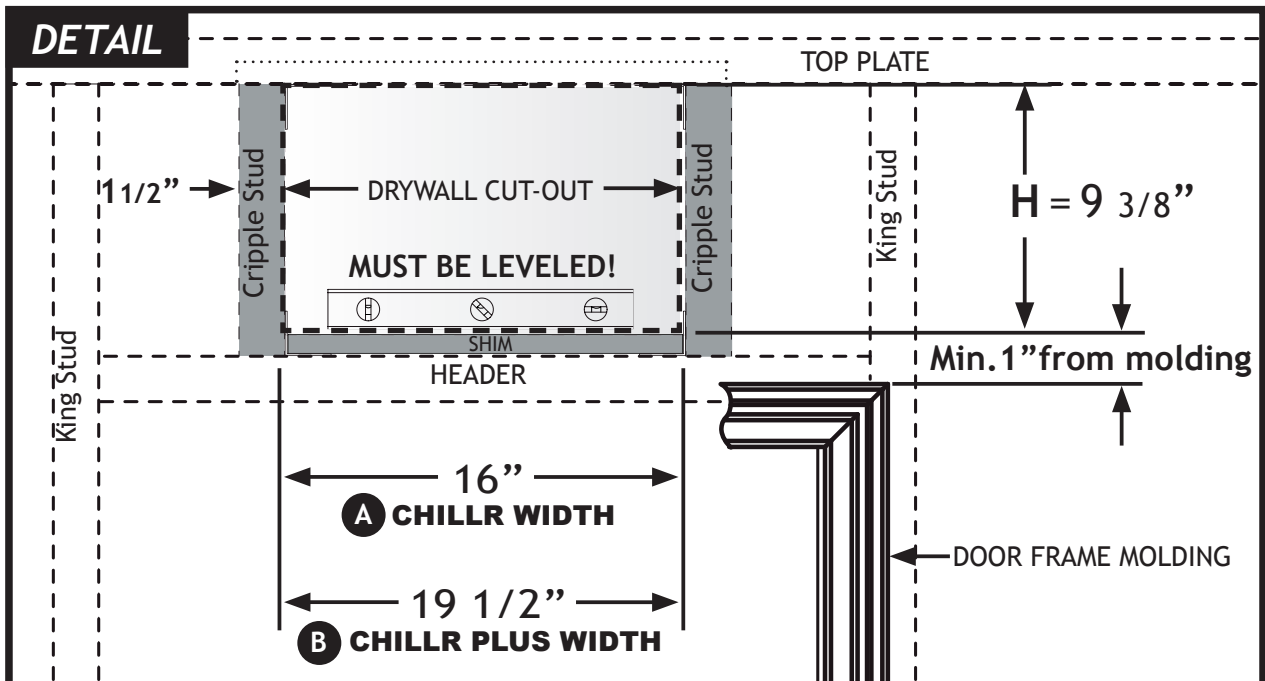
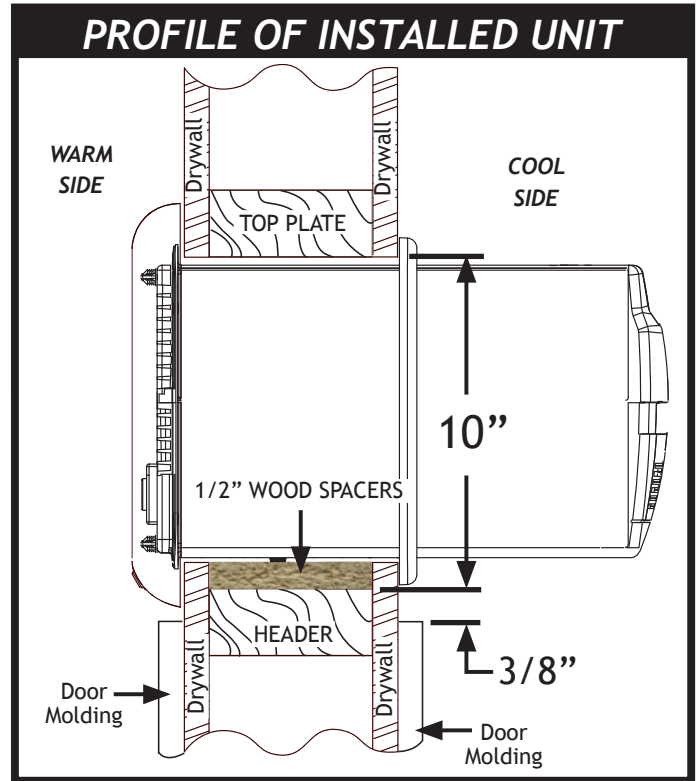

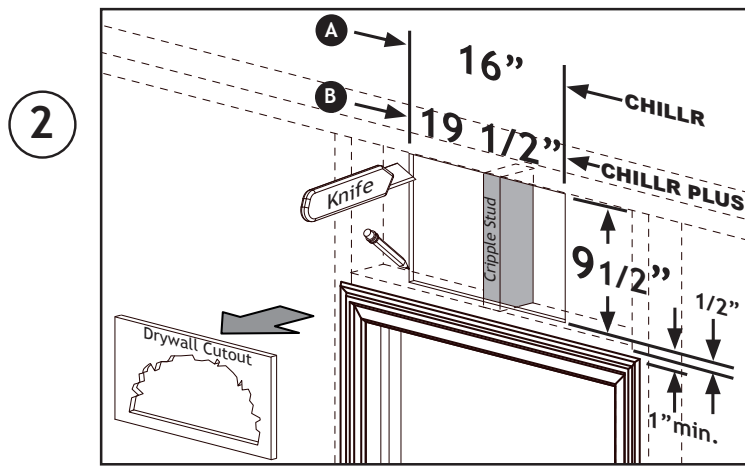

Depending on model, draw an outline for a cutout (16" x 9 1/2"). The bottom edge of the cutout must be 1/2" above the Header to allow for the Wood spacer insert. Make sure there is at least 7/8" clearance between door molding and cutout. If not, you will have to use a shim in step 6, cut drywall.

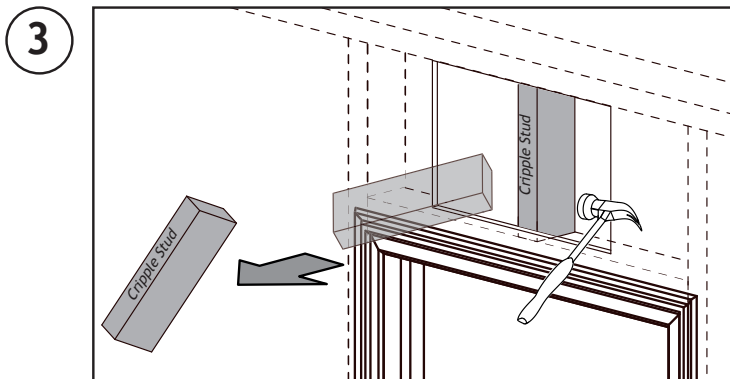

Remove any Cripple Stud located in the center above door

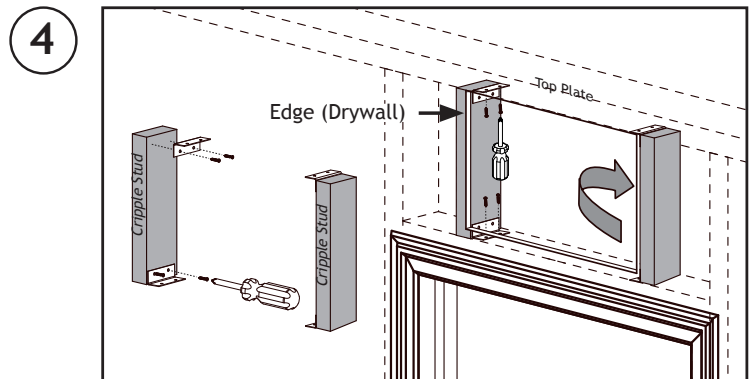

Screw (#6 x 1") in L BRACKETS to Cripple Studs, insert each one into wall cutout flush to Side Edge of drywall. Screw in Cripple Stud to Header and Top Plate.

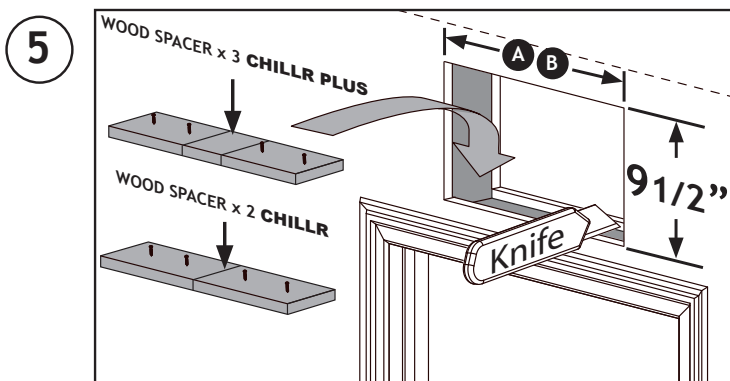

Cut out drywall hole on Cold side.
NOTE: Bottom Edge must be 1/2" from Header, use **WOOD SPACERS** as cutting guide.

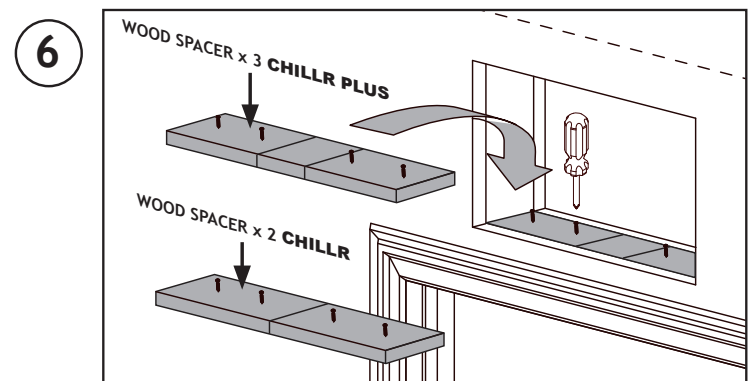

Check for level and shim if necessary or to achieve 1" clearance from molding. Screw (#6 x 1") **WOOD SPACERS** into Header flush with drywall on the warm side.
(SEE DETAIL)

B WALL CUTOUT

ADVANTAGE OF THE DESCRIBED INSTALLATION: The unit will be attached to a built in frame and placed on a Foam Vibration Isolator providing acoustic separation from the long vertical studs.
START FROM COLD SIDE

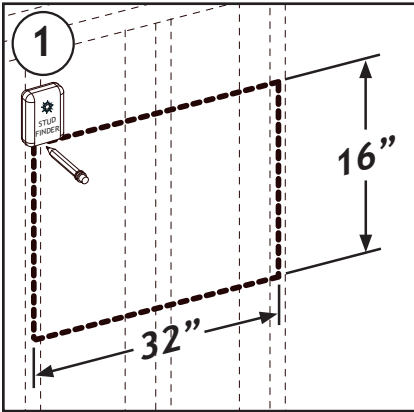

Use stud finder to locate studs and mark their location for Cutout hole.

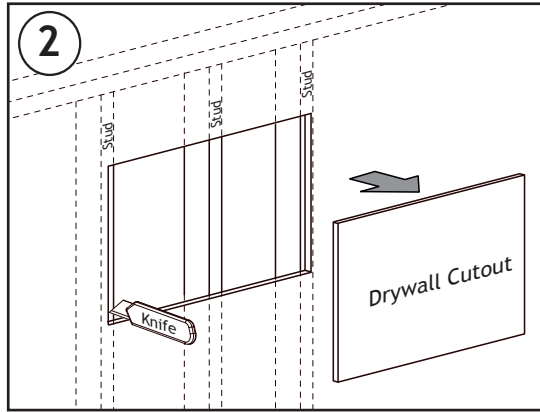

Cut out drywall, make sure to allow 1/2"-3/4" exposed stud for screwing in replacement drywall.

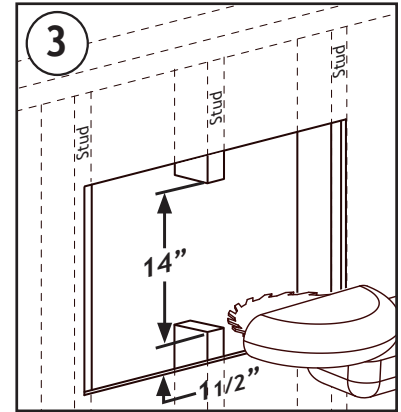

Cut out middle stud.
(SEE DETAIL)

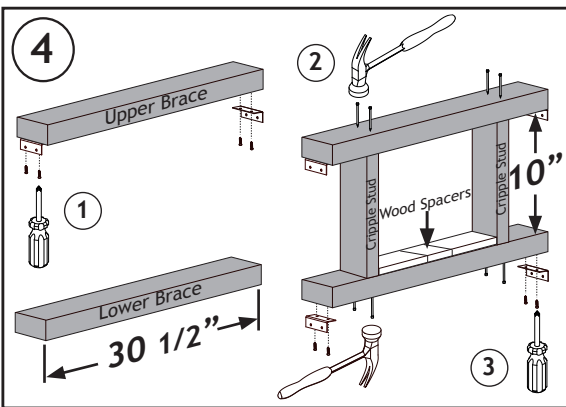

Assemble Frame using 2" x 4"s and attach L BRACKETS with (supplied #6 x 1") screws. Hint: use WOOD SPACERS for distance between Cripple Studs.

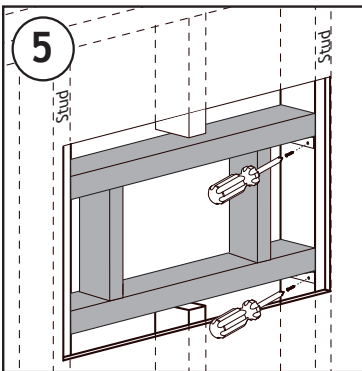
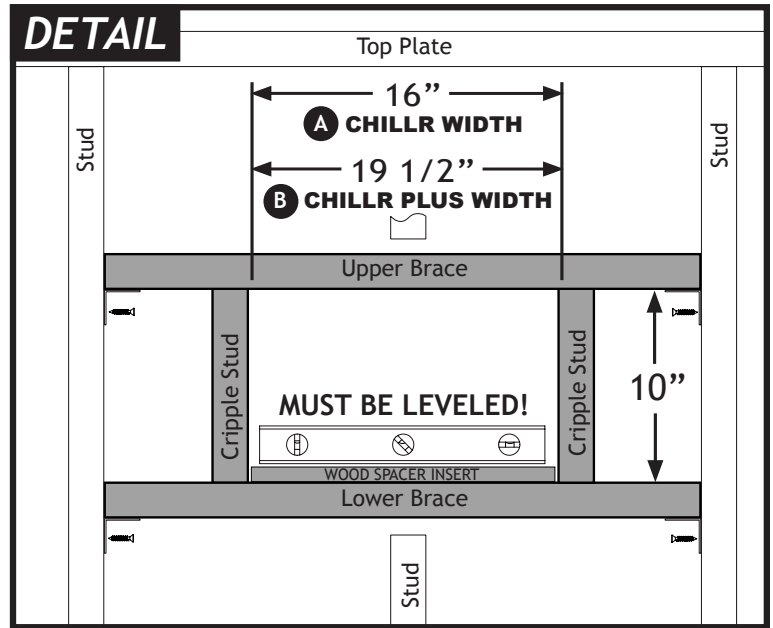

Level cooling unit frame and screw (#6 x 1") into vertical studs through L BRACKETS (Do Not rest frame on center stud) **(SEE DETAIL)**.

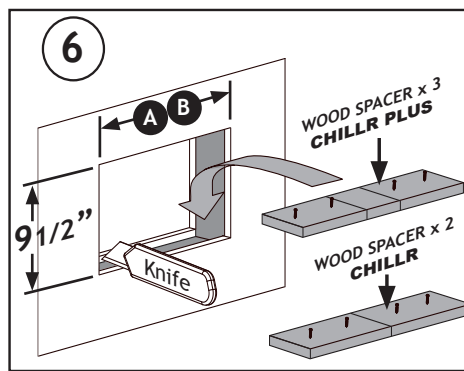

Cut new replacement drywall and cover hole. Cut out hole for cooling unit on both sides. NOTE: Bottom edge must be 1/2" from Lower Brace, use WOOD SPACERS for cut guide.

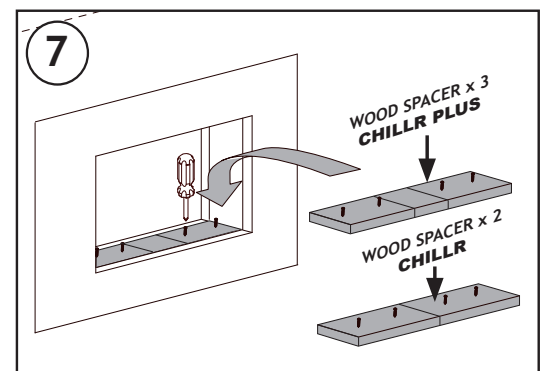

Screw (#6 x 1") WOOD SPACERS into Lower Brace flush with drywall on the warm side.

STEP 1 : INSTALLING COOLING UNIT

WARM SIDE
Outside of cool room

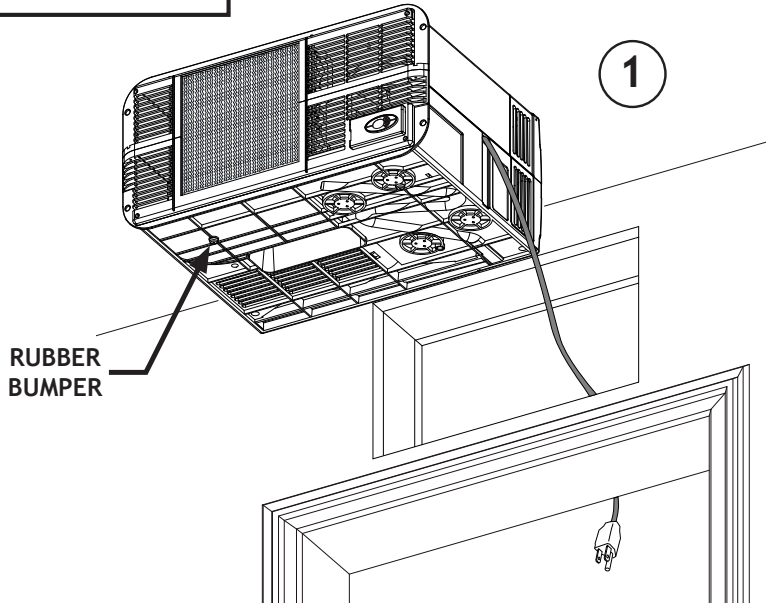

1

Place power cord through hole.

Center and place cooling unit through cutout on **WARM SIDE**.

IMPORTANT NOTE :

AVOID SHEARING OFF BUMPERS.

RUBBER BUMPER

2

Screw in 4 (#8 x 1 3/4") screws and washers into side flanges into wall studs.

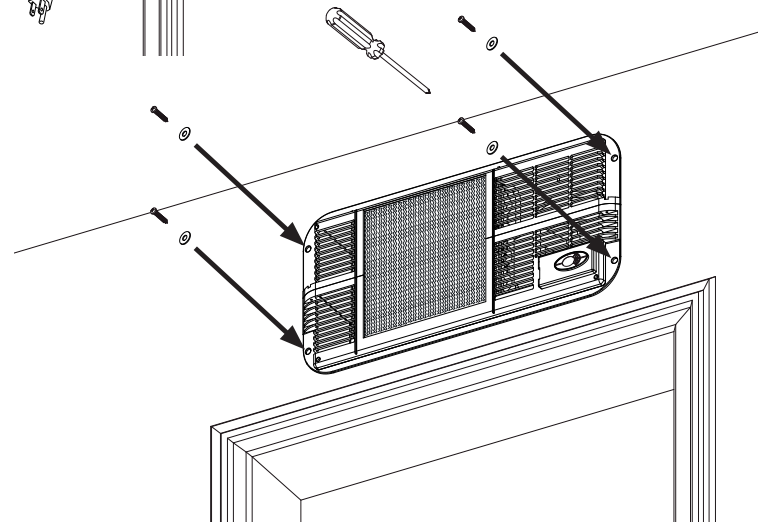

3

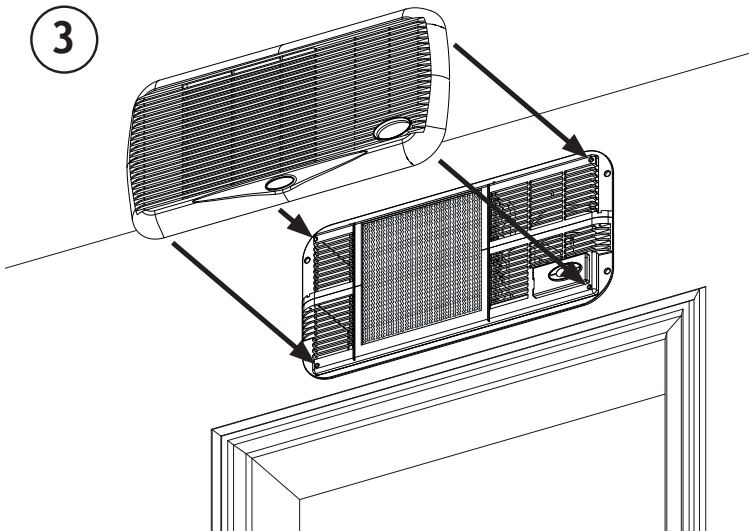

NOTE:

DO NOT FORCE OR YOU MAY DAMAGE PRONGS.

Center and gently push-on louver.

STEP 2 : INSTALLING REAR FRAME AND DRAIN PAN

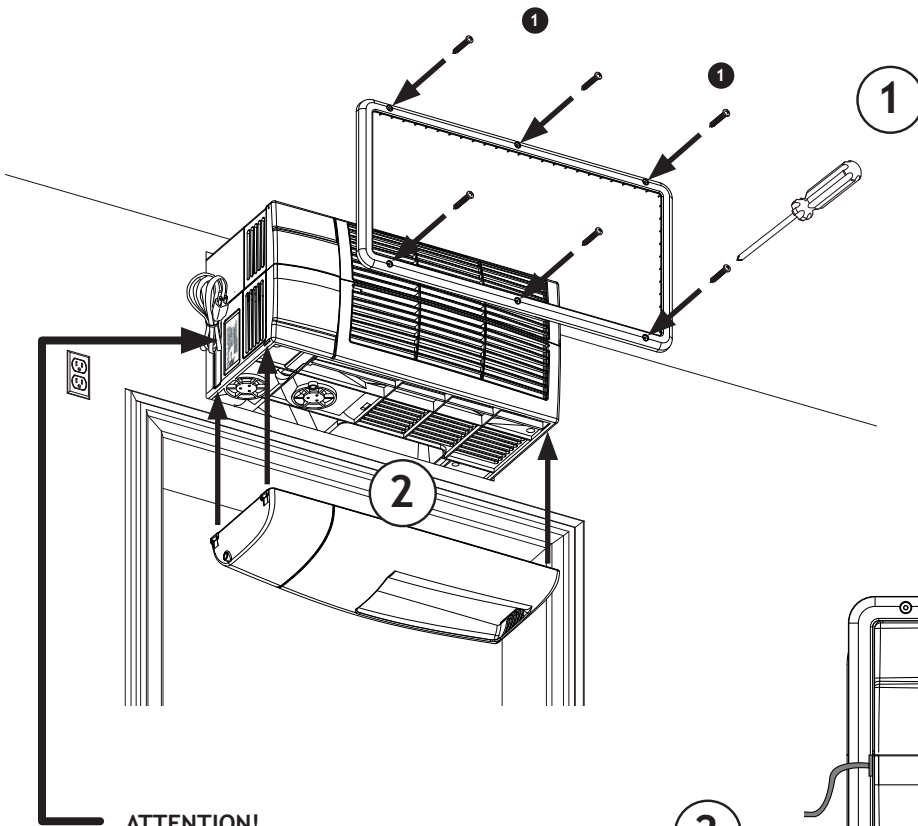

Slide Frame over rear of cooling unit.
Screw (#6 x 1 3/4") in frame to studs.
If ceiling obstructs installation screw in both (1) ends, only omit middle screw.

VERY IMPORTANT NOTE :

MAKE SURE THERE ARE NO GAPS AND THERE IS A GOOD SEAL ALL AROUND UNIT.

ATTENTION!

PLEASE WRITE DOWN THE SERIAL NUMBER ON THE WARRANTY REGISTRATION FORM.

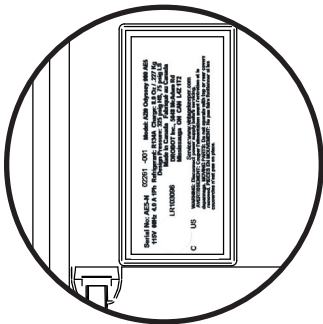

Insert Drain Pan by angling the Drain Pan:

1. Insert LEFT tabs first then
2. Push up RIGHT side to allow tab in.

2

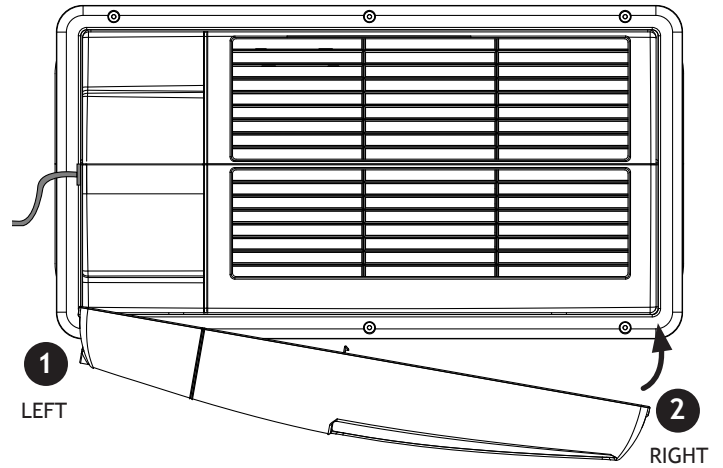

COOL SIDE

3

Plug in cooling unit.

DO NOT USE AN EXTENSION CORD!

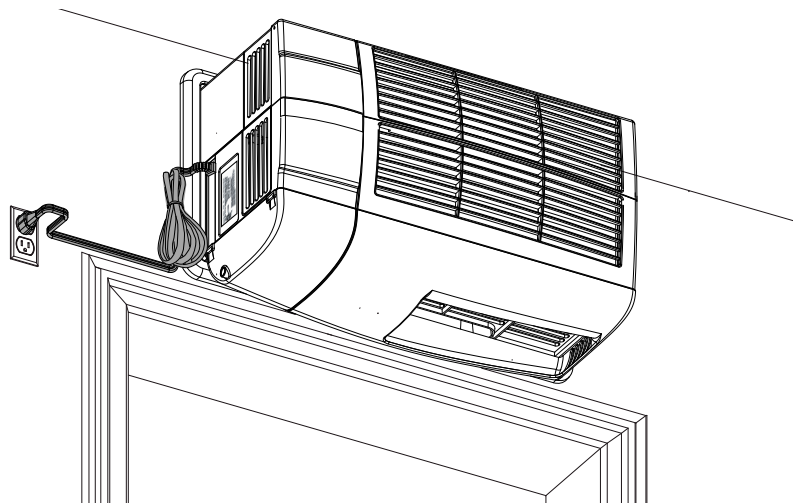

DRAIN PAN MAINTENANCE

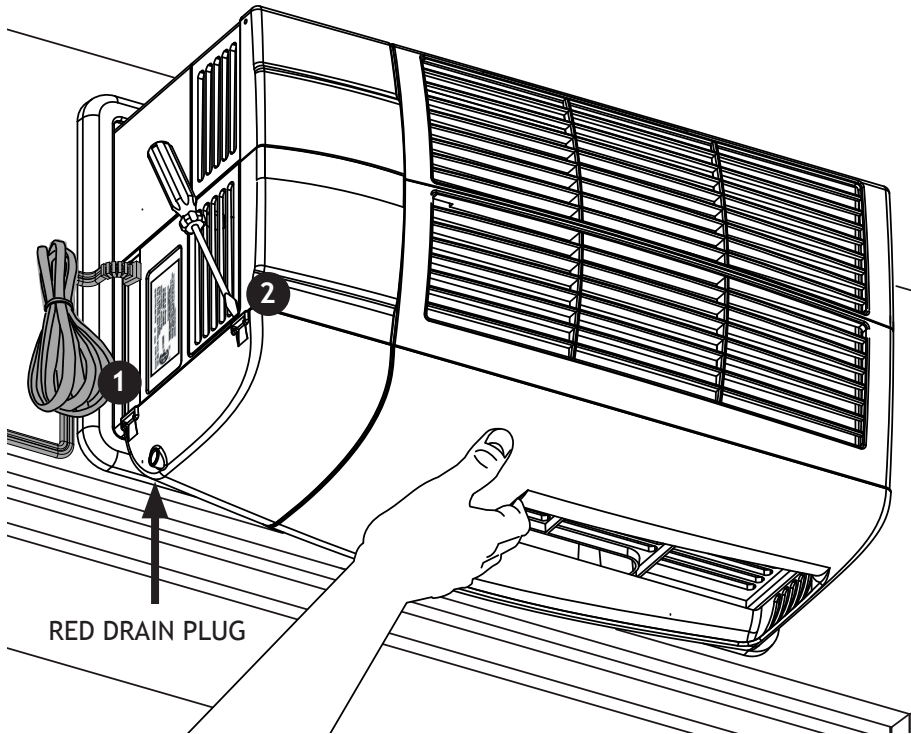

1

Remove Drain Pan with Flat screwdriver at TABS (1)(2) to release.

2

Dump out condensation water.

NOTE : EMERGENCY DRAIN IN EXTREME TEMPERATURES

Drain or evaporate the condensate?

FACT:

- condensate evaporators use a lot of costly energy and add heat to the system that can shorten the life of cooling units.
- Another important issue is the development of harmful spores and a requirement for time consuming and expensive cleaning and maintenance.

SOLUTIONS:

- Koolspace units are designed with multi stage systems; Internal evaporation using the natural heat of the unit. Externally the unit is equipped with a pan and the ability to drain under extreme temperature and humidity conditions into a larger container using a 3/8" O.D. hose. (A properly designed room should not overflow drain pan)

NOTE:

Excess condensation is caused by extreme conditions. Unit will shut off at 72° F and will restart when temperature drops or unit is re-plugged (wait 5 seconds after pulling out plug then re plug). **Empty drain pan before re-plugging.**

If Drain Pan fills frequently do the following:

Remove **RED DRAIN PLUG** and insert a hose into drain hole and cut to length. Place drain hose into a large container.

IMPORTANT NOTE :

When leaving the house for an extended period of time do the above to insure your wine. Make sure the DOOR is CLOSED and ROOM is totally SEALED from any air leakage.

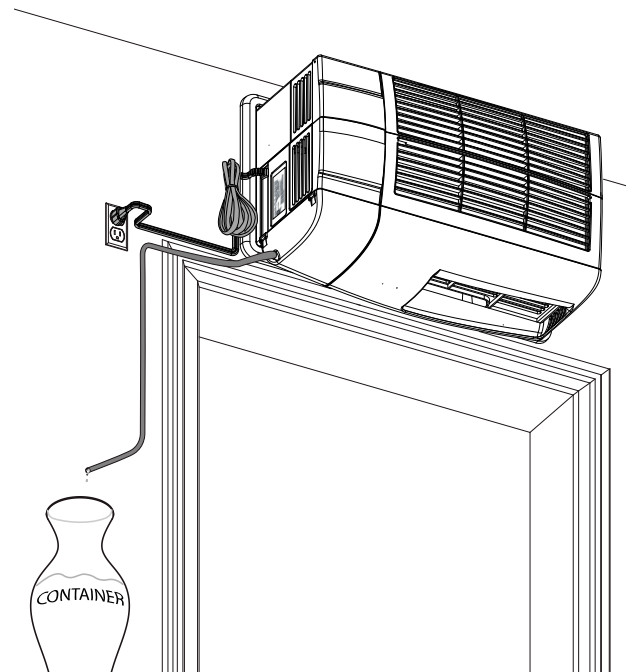

CONTROLS : PLUG IT IN (wait one minute) and ENJOY!

- FEATURES:**
- Default SET temperature 57° F/14° C (ideal for wine storage).
 - Calibration option of the temperature sensor.
 - Display of actual temperature by request.
 - SET temperature range 52°F-64°F.
 - Accurate temperature sensor.
 - Dual display F°/C°.
 - Settings are stored in memory for power failures.
 - Pre programed software will reach the quietest most efficient operation.



- OPERATION:**
- The display will show the detected temperature until the temperature will fall within 3° of the SET POINT.
 - If the temperature is above the default 57° F + 1° or other preset value, after a **delay of 1 minute** the fan will start, followed by the compressor within the next minute.
 - The unit will cycle ON/OFF based on the temperature reading. Fan speeds are automatically set by the controller to achieve optimum performance.
 - Minimum ON and OFF cycle times are imposed by software, to prevent "short cycling".

CONTROLLER OPERATION	ACTION	DISPLAY EXAMPLE	
		BEFORE	AFTER
TO DISPLAY:	Actual temperature: PRESS ▲	57°	56°
	SET temperature: PRESS ▼	70°	57°
TO MODIFY SET TEMPERATURE (range is 52-64°F):	PRESS and RELEASE ▼	57°	57°
	To increase: PRESS ▲ once per degree	57°	58°
	To decrease: PRESS ▼ once per degree	57°	56°
	The new value will be memorized and the controller will reset automatically.		
TO CHANGE FROM °F to °C or °C to °F	PRESS and HOLD ▼ until buzzer sounds in 5 seconds	57°	14°
	The new value will be memorized and the controller will reset automatically.		
TO CALIBRATE:	PRESS and HOLD ▼ while holding PRESS ▲ and RELEASE	57°	57°
	Wait 5 seconds	57°	F0
	USE ▲ or	F0	F1
	▼ for each degree of offset	F0	-1
NOTE: A negative offset ▼ will result in a warmer cabinet and a positive offset ▲ will result in a cooler cabinet. The new value will be memorized and the controller will reset automatically.			

SAFETY FEATURES:

- ALARM:**
- If the temperature exceeds 72° F the unit will shut down, a sound warning will start and the display will blink *AL* alternating with the temperature reading.
 - This function is disabled in the first 4 hours "Cool Down" period or after any reset for another 4 hours.
 - The unit will restart and continue the cooling and cycling if the temperature falls below 72° F.

- TO RESET:**
- Unplug and re plug the unit.

TROUBLE SHOOTING GUIDE

Koolspace™ cooling unit has been carefully tested at every stage of manufacturing. Please note that many problems result from rough or careless handling during shipping or installation, improper insulation of your room, power interruption or surge, low line voltage (less than 105V), or failure to clean the unit regularly. The following may help you determine what the problem may be, what steps you can take to correct it, and what further steps may be required. Additional Trouble-Shooting information and downloadable documents are available in the "Support" area of our web site: www.koolspace.com

CONDITION	CHECK	CAUSES AND SOLUTIONS
<p>COOLING UNIT DOES NOT RUN WHEN PLUGGED IN</p>	<ul style="list-style-type: none"> ● Unit plugged in? ● Power supply operational? ● LED display functional and are fans running? ● Any evidence of shipping damage on the cooling unit or packaging materials? 	<ul style="list-style-type: none"> ● Unit has a 1-min. cautionary delay between plugging in and full start-up; this is a built-in safeguard to protect compressor in of a sudden power failure. ● Use a dedicated, separately fused and grounded 15 Amp, 120V line (Europe; 10-Amp 220 Volt). Do not use an extension cord. Do not share outlet with other appliances. ● Unplug Unit, remove controller, check replaceable fuse (0.5A SLOW BLOW, 250V, 5X20mm) in the controller. ● Unit receives power yet fans or compressor fail to run, unplug for ten minutes, then re-plug.
<p>COOLING UNIT RUNS BUT DOES NOT COOL SUFFICIENTLY</p>	<ul style="list-style-type: none"> ● Storage temperature properly set? ● Room properly constructed with all joints airtight? ● Door properly adjusted to seal tightly when closed? ● Airflow to and from the cooling unit unobstructed? ● Ambient air temperature within the specified range? 	<ul style="list-style-type: none"> ● Unit may take a few days to achieve the desired storage temperature. ● Take steps to reduce ambient temperatures outside wine room, compensate for additional heat gain if walls receive direct sunlight. ● If gaps are visible seal joints airtight. ● Improve circulation of air to and from the unit as directed in instructions. ● Make sure door is sealed tightly. ● Decrease your SET TEMPERATURE. ● Clean the grill areas. ● If the problem persists, go to our website at www.koolspace.com and perform the "cooling unit diagnostic" in the support section.

IMPORTANT NOTE:

- Have your wine collection adequately insured.
- Install a battery-powered heat-sensitive alarm to warn of any loss of cooling due to power interruption.
- Monitor your storage and ambient conditions on a regular daily basis.
- Install a high quality surge suppressor to protect against sudden power fluctuations.
- Clean the unit as directed regularly, every 3 to 4 months vacuum the cooling unit coils.

**CLEANING THE COIL:
VACUUM PERIODICALLY**

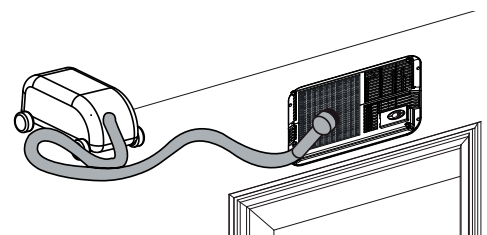

Be advised Koolspace™ cannot in any event be liable or responsible for incidental or consequential damages.

LIMITED WARRANTY AND PRODUCT SUPPORT

ONE YEAR LIMITED WARRANTY

If your Koolspace cooling unit or cabinet fails to perform as designed within one year of the date of purchase, VINTAGE KEEPER INC. warrants that, upon your request, it will be repaired or replaced, at our option, during the one year warranty period. This warranty applies only to the first end-user purchaser of a Koolspace unit that is purchased and used in the continental United States or Canada (excludes Alaska and Hawaii). It is not valid for subsequent purchasers, nor for units in use outside North America. The warranty period for your Koolspace unit commences on the date you purchased it and expires one year thereafter.

PROOF OF PURCHASE

Within 10 days of purchase, complete and mail, fax or e-mail the registration sheet to VINTAGE KEEPER INC. Alternately, you may register your warranty on our Internet web site, www.koolspace.com. **WHEN YOU MAKE A WARRANTY CLAIM, YOU MUST FORWARD A COPY OF YOUR ORIGINAL DATED BILL OF SALE TO ESTABLISH YOUR DATE OF PURCHASE.**

IF YOU HAVE A PROBLEM WITH YOUR UNIT

Customer service and warranty problems are handled online at www.koolspace.com. You will find a comprehensive well-documented and easy-to-use solution to almost any question or problem you may have. The inquiry forms are filled in on-line and connect you to our representatives who will process your requests for warranty service. This is the quickest way to solve your problems. If you do not have access to the internet you may call us from 9:00 a.m to 4:00 p.m EST, to request a WARRANTY CLAIM INFORMATION KIT. We can fax or mail it to you. You can fill in the enclosed REQUEST FOR RETURN AUTHORIZATION CODE form and return it by mail or fax. We can then promptly process your claim.

REPLACEMENT ?

At our option we may choose to offer you a replacement part or product rather than a repair. Upon your authorization to accept a replacement unit and with appropriate security (credit card authorization), we will promptly ship a replacement unit. The replacement may be a unit that has been reconditioned by VINTAGE KEEPER INC. The unit that needs service must be packed and returned to us, shipping prepaid. Upon its receipt, we will release your credit card security. Go online to the SUPPORT section on our web site at www.koolspace.com to request warranty service.

REPAIR ?

If we determine that your unit needs to be repaired rather than replaced we will issue you a Return Authorization Code. Go online to the SUPPORT section of our web site at www.koolspace.com to request warranty repair service. Please save the original packaging materials to facilitate shipment. Mark the Return Authorization Code clearly on the outside of the package, enclose a brief note describing the problem and send the unit, shipping prepaid, to VINTAGE KEEPER INC.

WHAT MUST YOU DO?

Your unit is designed to perform with a minimum amount of user maintenance when installed and operated precisely as directed in the manual. You are, however, responsible for the required user maintenance described in the manual, specifically, regular cleaning of the condenser coil and fans. Also, you must take steps to protect the unit from sudden power surges. As with any sensitive electronic device, your Koolspace unit may be damaged by power surges or spikes, including lightning strikes, acts of god, sudden interruptions or prolonged low-voltage conditions, which are not covered by this Warranty. You must monitor your unit's performance on a daily basis. If there is an apparent problem or "Alarm" condition, you must disconnect the power supply to avoid potential damage to your wine collection. It is your responsibility to insure your wine, and to take all reasonable and necessary precautions to safeguard its condition.

WHAT THE WARRANTY DOES NOT COVER

This warranty covers only defects in materials and workmanship provided by VINTAGE KEEPER INC. and does not cover equipment damage or malfunction from misuse, abuse, accident, act of God, or any unauthorized alteration or modification. The product must have been installed and operated precisely as directed in the manual which accompanies each product. Improper return shipping, inadequate packaging or shipping damage is not covered unless the unit is packaged and shipped in accordance with Koolspace replacement procedures. Third party servicing of this product during the warranty period will also void the warranty, as will any evidence of tampering or alteration to the serial number and or the original dated bill of sale.

REPLACEMENT AND REPAIR ARE YOUR ONLY REMEDIES

YOUR ONLY REMEDY UNDER THIS WARRANTY IS THE REPLACEMENT OR REPAIR OF YOUR ELIGIBLE PRODUCT AS DESCRIBED ABOVE. NEITHER THIS WARRANTY NOR ANY OTHER WARRANTY, EXPRESS OR IMPLIED, INCLUDING, BUT NOT LIMITED TO, THE IMPLIED WARRANTIES OF MERCHANTABILITY AND FITNESS FOR A PARTICULAR PURPOSE, SHALL EXTEND BEYOND THE ONE-YEAR WARRANTY PERIOD. UNDER NO CIRCUMSTANCES SHALL VINTAGE KEEPER INC. BE LIABLE FOR ANY SPECIAL INCIDENTAL, INDIRECT OR PUNITIVE DAMAGES OR FOR ANY CONSEQUENTIAL DAMAGES, INCLUDING SPOILAGE OF WINE, EVEN IF VINTAGE KEEPER INC. KNOWS OR IS INFORMED THAT SUCH DAMAGES ARE POSSIBLE. IT IS YOUR RESPONSIBILITY TO INSURE YOUR WINE, AND TAKE ALL REASONABLE, NECESSARY PRECAUTIONS TO SAFEGUARD ITS CONDITION. SOME STATES DO NOT ALLOW THE EXCLUSION OR LIMITATION OF INCIDENTAL OR CONSEQUENTIAL DAMAGES, SO THE ABOVE EXCLUSION OR LIMITATION MAY NOT APPLY TO YOU. NO RESELLER IS AUTHORIZED TO MODIFY THE TERMS OF THIS WARRANTY. ANY ADDITIONAL WARRANTY OFFERED BY A RESELLER IS THE SOLE RESPONSIBILITY OF THAT RESELLER.

SERVICE AFTER YOUR WARRANTY EXPIRES

If your unit requires service after the one-year warranty period expires, you may have it serviced locally by any qualified HVAC technician, or you may purchase a new unit at a special discount under our Extended Warranty Program. Please be ready to provide model, serial number, credit card number and a copy of your original dated bill of sale. In addition, repair service is always available direct from us at flat rates below the prevailing charges for local service. However, using our Extended Warranty Program for units under 5 years old will always be a preferable solution to returning a unit for repair. Go online at www.koolspace.com to request Repair Service or see our Extended Warranty Program.

www.koolspace.com

For sales and customer service call toll free: 1-888-274-8813